

The Use of an Acoustic Lens to Control the High Frequency Dispersion of Conventional Soft Dome Radiators

by David Moulton

*Presented at the American Loudspeaker Manufacturers Association Symposium,
Las Vegas, NV, January, 1998.*

Abstract

The beam width of conventional direct radiators varies as a function of wavelength and frequency, leading to loudspeakers whose directivity varies widely as a function of frequency. At the same time, flat frequency response across an horizontal angle of 180° yields significant benefits in terms of imaging, timbre and room interface. The authors will discuss a lens that converts the output of a conventional radiator into such a dispersion pattern.

Précis

The Dispersion Problem

The dispersion of direct radiators varies as a function of frequency, tending to diminish as the frequency increases. This behavior is a direct result of the coupling of a direct radiator to open air. At wavelengths that are long relative to the size of the radiator, the dispersion of energy will tend to be omnidirectional, while at short wavelengths it will tend to be directional.

This means that, for a transducer with flat amplitude response on axis, at low frequencies (long wavelengths) the power output will be significantly greater than it is at high frequencies. By itself, this means that loudspeakers in reverberant rooms have deficient high-frequency performance, because the summed direct and reverberant energy from a loudspeaker have a power spectrum that is rolled off compared to the power spectrum detected by a microphone used to make a recording intended for playback over that loudspeaker. Further, when loudspeakers are used in stereophonic pairs, the absence of high-frequency lateral dispersion diminishes the quality of the stereophonic illusion, because the lack of high-frequency information in the reflections reduces the clarity, robustness and depth of the perceived phantom images.

Traditional Design Practice For Dealing With Dispersion

Direct radiators are traditionally mounted in baffles. The dispersion characteristics of any given mounted driver are either accepted as is, or else “smoothed” by the use of gentle and conservative wave guides which are intended both to reduce diffraction effects and to make dispersion more uniform and/or narrow. Some manufacturers attempt to reduce baffle size to enhance dispersion. In general, high-frequency dispersion of +/- 15° at a -6 dB point is considered acceptable, +/- 30° at a -6 dB point is considered to be good performance, and +/- 45° at -6 dB is considered to be excellent in conventional loudspeaker performance. Generally, no modifications to the transducer itself are undertaken to modify driver dispersion.

Acoustic Lens Technology In Principle

Acoustic Lens Technology (ALT) incorporates a lens and a conventional soft dome radiator into an integrated unit, so that the actual dome is partly enclosed in a concave chamber and partly enclosed in a convex chamber that is exposed to free space. The geometry of the lens is based on a radial continuum of elliptical sections that in combination create what can be thought of as a “wave-gathering-and-spreading mechanism.” The lens redirects the acoustic energy by 90°, so that in a normal application, the driver is facing upwards and the lens directs the sound into a horizontal dispersion field approximately 180° wide and a vertical dispersion field approximately 30° high.

The power output of a driver is normally radiated into free space (yielding power coverage of approximately 270° by 270° on average) with the great majority of that power output in the lower frequency range of the driver. The ALT lens redirects the power into a much smaller solid angle, approximately 30° by 180° as noted above. At short wavelengths the lens acts approximately as a ray-tracing reflective device. At longer wavelengths, the lens functions in a manner somewhat analogous to a horn, leading to increased directionality at such wavelengths and frequencies. Interference effects and phase problems are minimized by the elliptical geometry at higher frequencies and by the comparatively long wavelengths (i.e. reduced phase shift per unit of time delay) at lower frequencies.

In summary, the power output of the driver is radiated into a comparatively small solid output angle of 180° by 30°, is comparatively free of lobing and other interference effects, and is approximately constant as a function of frequency.



Acoustic Lens Technology In Application: Two Lenses In A Three-Way System

A successful three-way prototype run has been constructed that employs ALT lenses for the midrange and high-frequency drivers. The drivers are high quality commercially available drivers, and the lenses were optimized to match their behaviors.

Crossover frequencies are lower than would be normal for these drivers, at approximately 300 Hz. (normally about 800 Hz.) for the woofer/midrange crossover point, and 1800 Hz. (normally 4 kHz.) for the midrange/tweeter. Because of the constancy of the dispersion and the minimal phase shift problems, the crossover points are extremely smooth on and off axis, and the family of response curves at 0°, 30°, 60° and 90° in the horizontal axis are extremely similar, albeit with a slight loss in relative level at 90° of about 6 dB.

1U.S. Patent No. 5615176

Commercial Development

As we have developed this lens, it has become clear to us that the lens is more properly thought of as a modification to driver technology than to loudspeaker system design. The performance of the lens is absolutely related to the performance of the driver, and the development of any particular driver/lens combination needs to be carried out prior to its incorporation into any loudspeaker system. Such a developed driver/lens can then be specified for use in loudspeaker systems.

The actual horizontal and vertical dispersion characteristics of the lens can be modified for different applications, given a suitable driver. Specifically, the vertical dispersion can be changed for various applications, while retaining broad horizontal dispersion. For sound reinforcement applications, for instance, extremely thin but wide dispersion can be obtained, while in a fixed close environment such as an automobile, vertical dispersion can be increased to accommodate a broad range of listener head heights.

In a fully developed and finished form, an ALT driver/lens can be easily incorporated into a wide range of loudspeaker systems. It is suitable for applications such as conventional high fidelity loudspeakers, home theater speaker arrays, in-wall speakers for distributed sound systems, automobile sound systems, and concert sound reinforcement applications.

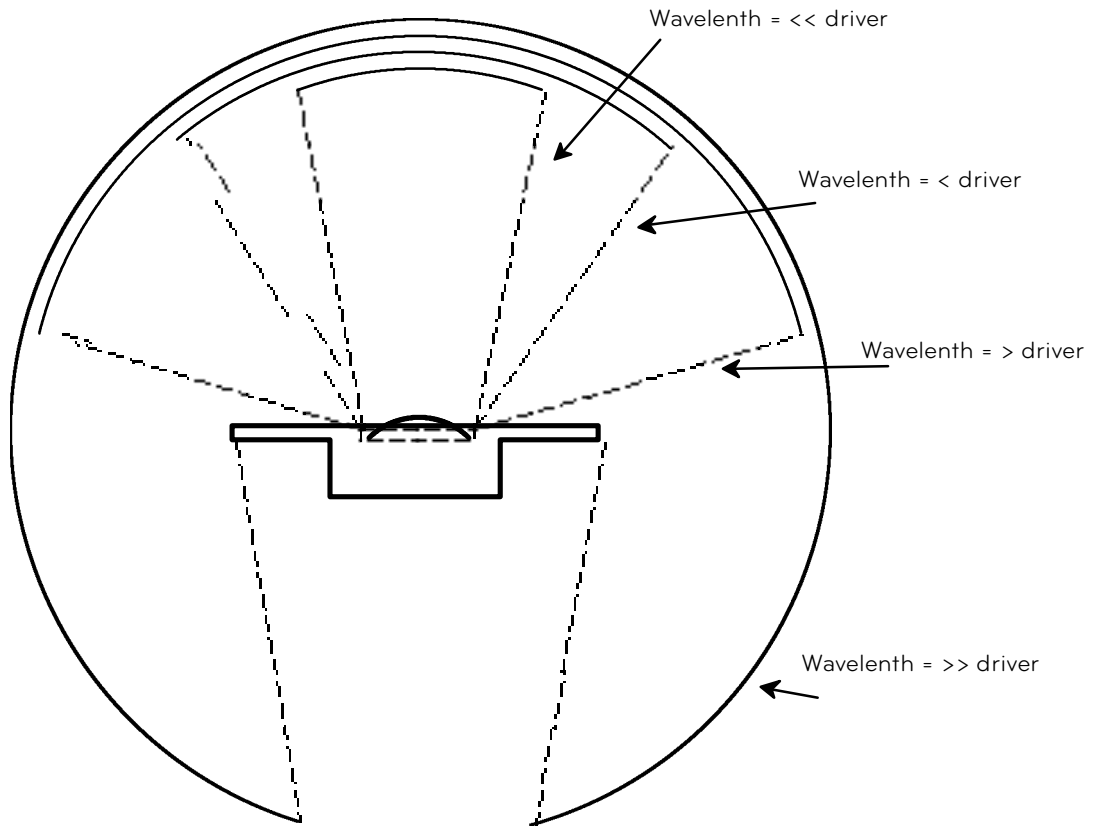

Figure 1: Generalized dispersion of a direct radiator as a function of wavelength versus driver size.

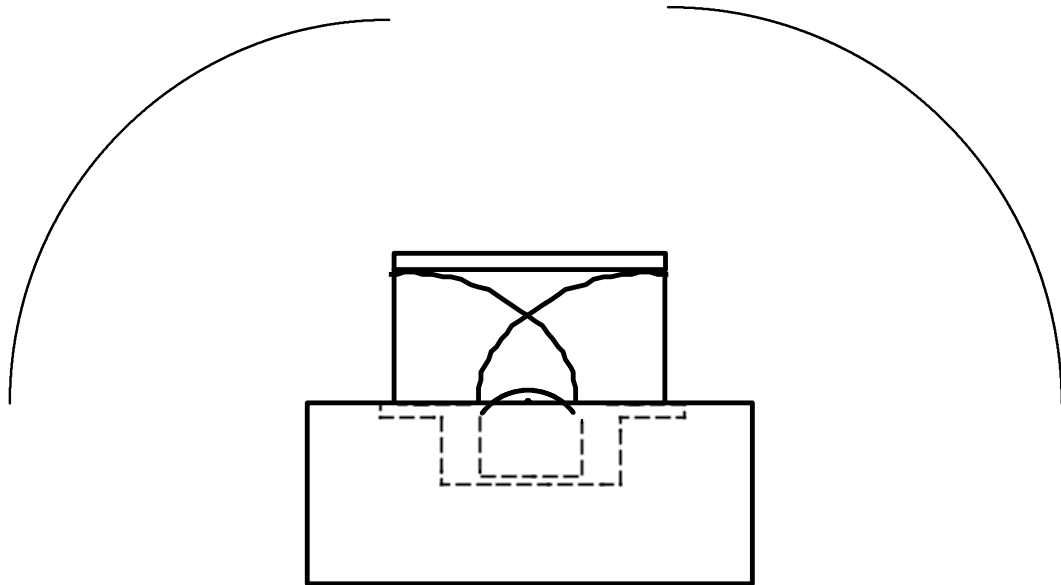

Figure 2: Front View of upward-facing driver in baffle firing into ALT lens. The concave chamber is immediately above the driver, and the convex section of the lens is above that. The geometry of the lens is derived from a section of the envelope of an ellipse, and the acoustical center of the driver is at a common focal point of that ellipse.

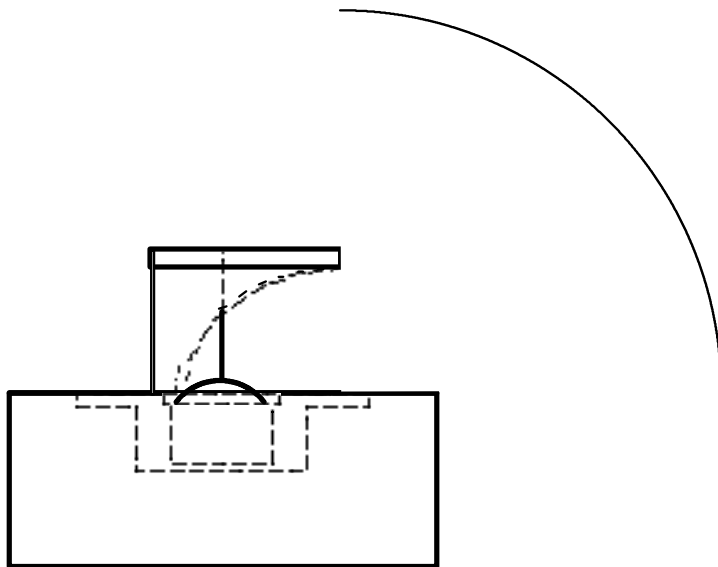

Figure 3: Side view of upward-facing driver in baffle firing into ALT lens.

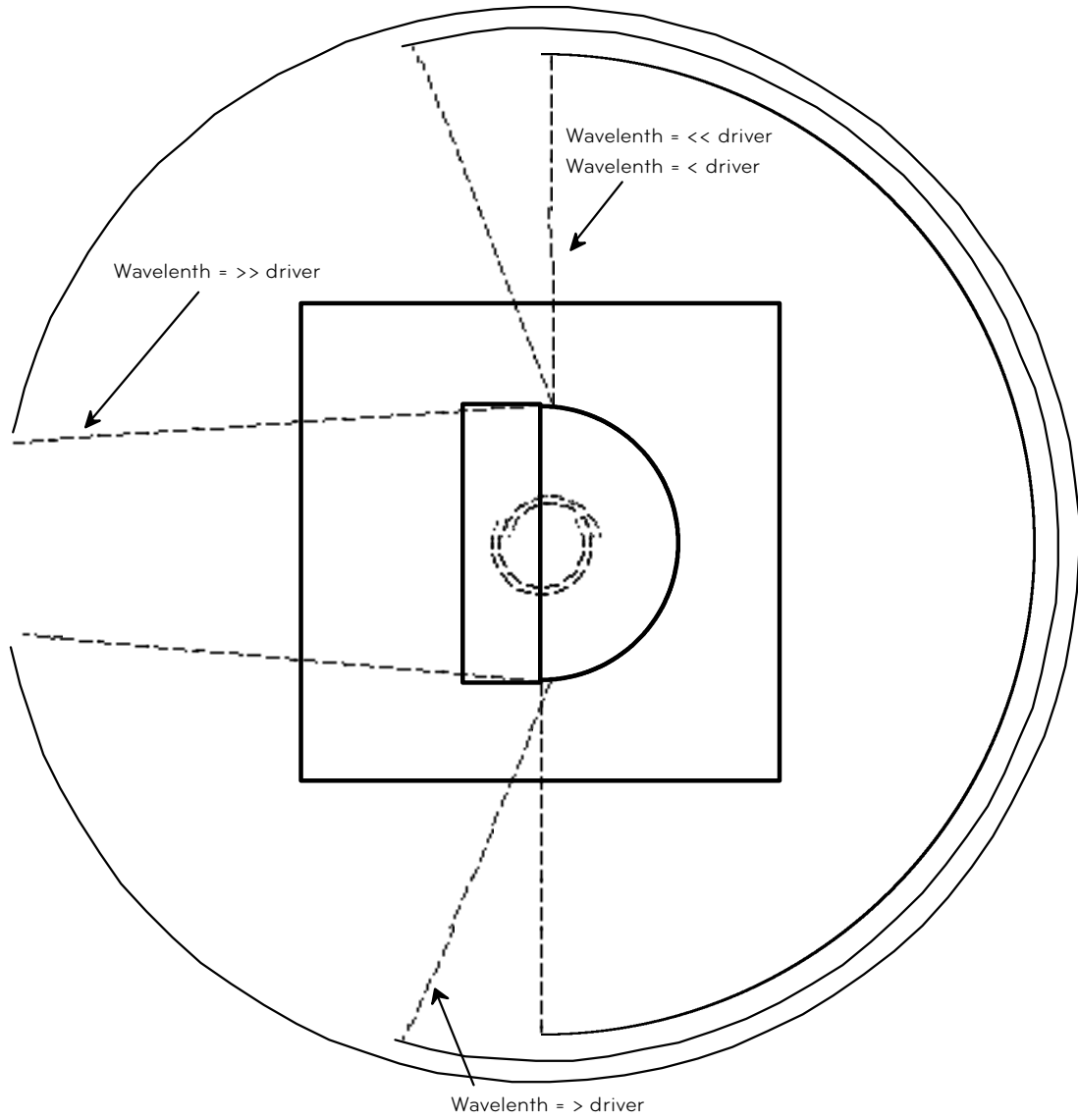

Figure 4: Overhead view of generalized horizontal dispersion from ALT lens as a function of wavelength versus driver size.

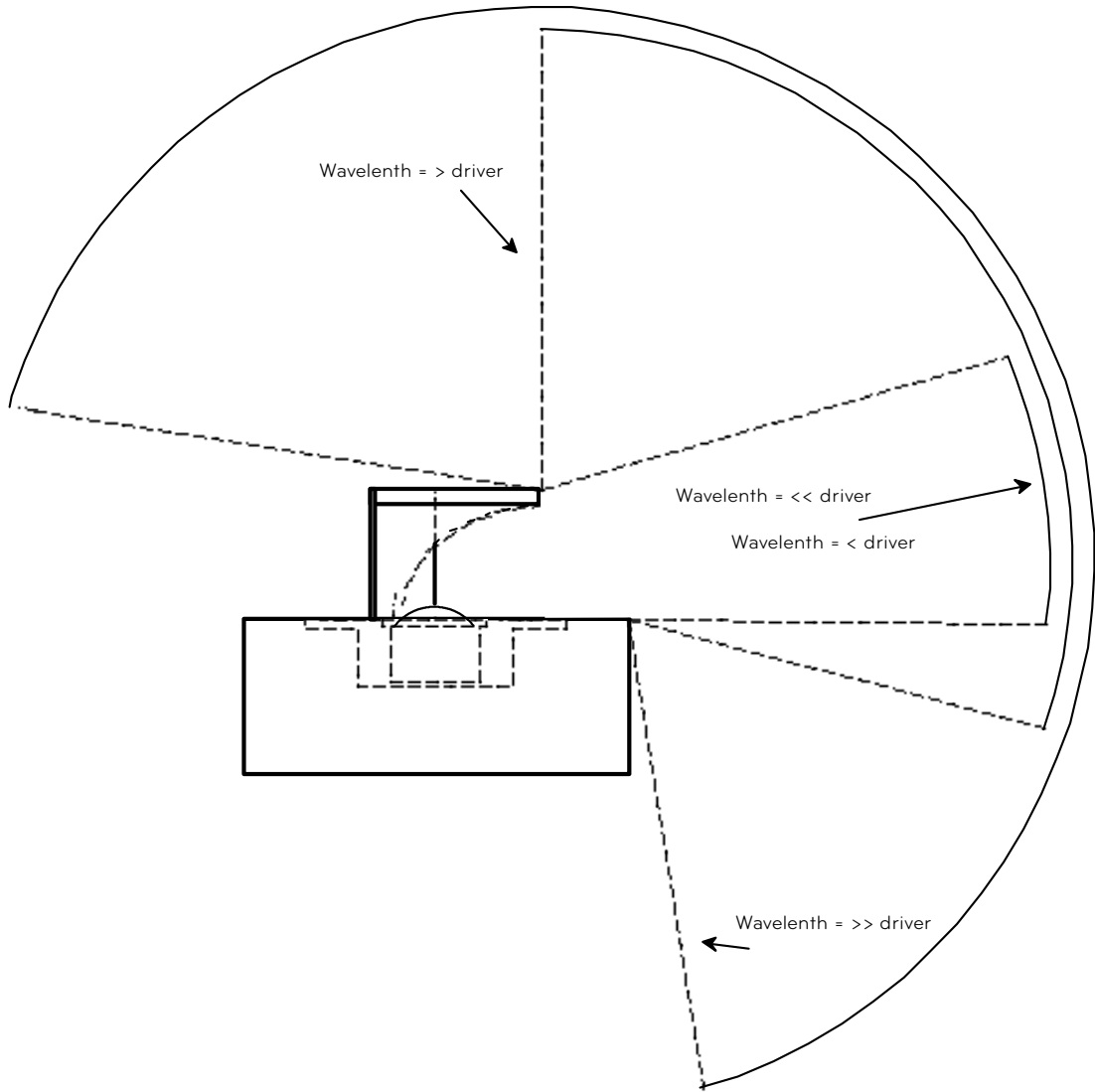

Figure 5: Side view of generalized vertical dispersion from ALT lens as a function of wavelength versus driver size. Note that within the dispersion zone for short wavelengths, some asymmetry will be encountered.

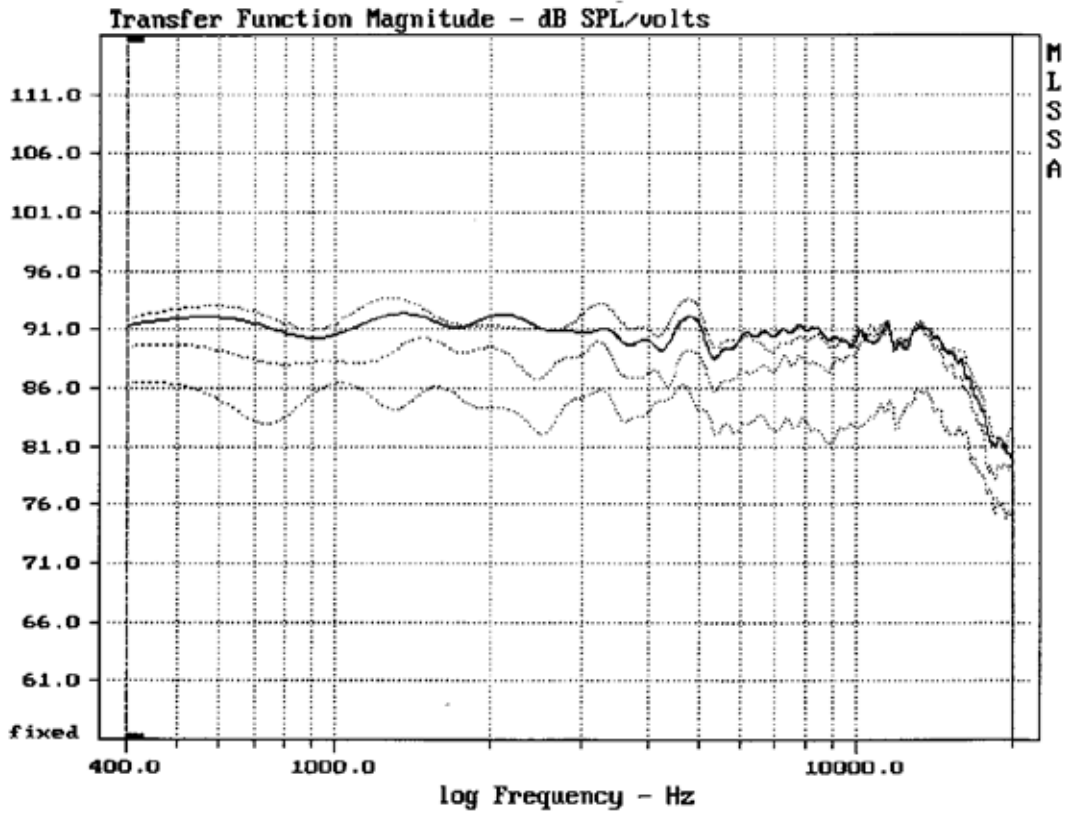

Figure 6: Quasi-anechoic response of 3-way prototype at 0°, 30° (the design axis), 60° and 90° using ALT lenses for midrange and tweeter sections.

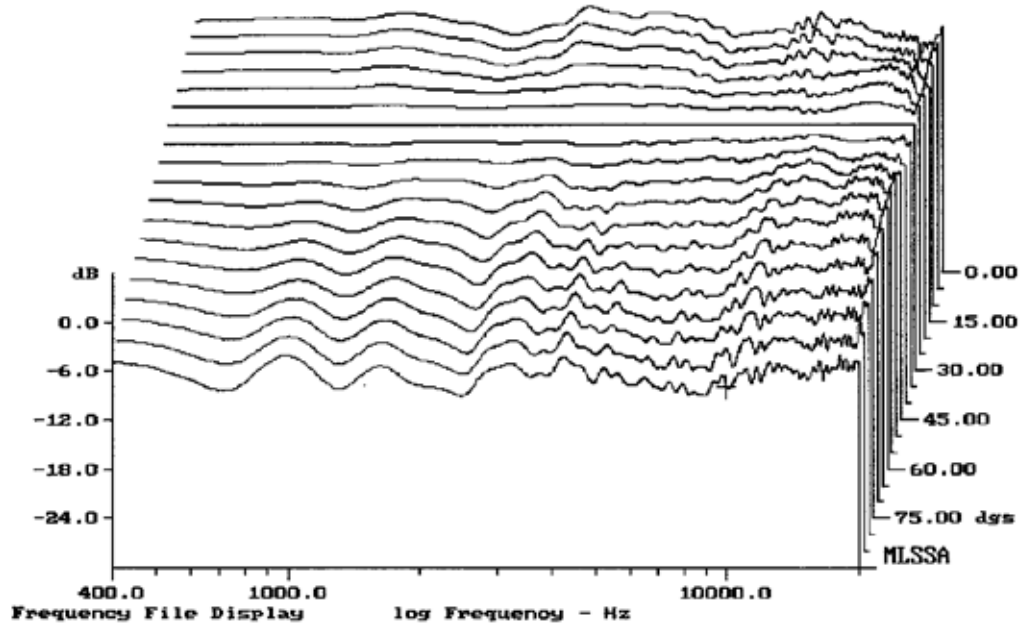

Figure 7: "Polar Waterfall" of 3-way prototype using ALT lenses for midrange and tweeter. Curves in 5° increments from 0° to 90°, normalized to the design axis of 30°.